

## WARP STOP MOTIONS AN OVERVIEW



Higher machine operating speeds, increased weaving widths, improved performance: New weaving machines are becoming ever more productive. To ensure optimised fabric quality, Groz-Beckert offers a range of ideally configured warp stop motions. These are capable of fully accommodating ever more stringent demands while reducing demands on operating personnel. The result: more cost-effective production coupled with top class fabric quality.

## KFW 5600 – ADVANTAGES



DIVIDED CONTACT BARS KFW 5620 / 5621.



OPTICAL THREAD BREAKAGE DISPLAY WITH PROGRAMMABLE SIGNAL PROCESSOR (PSP) KFW 5600.

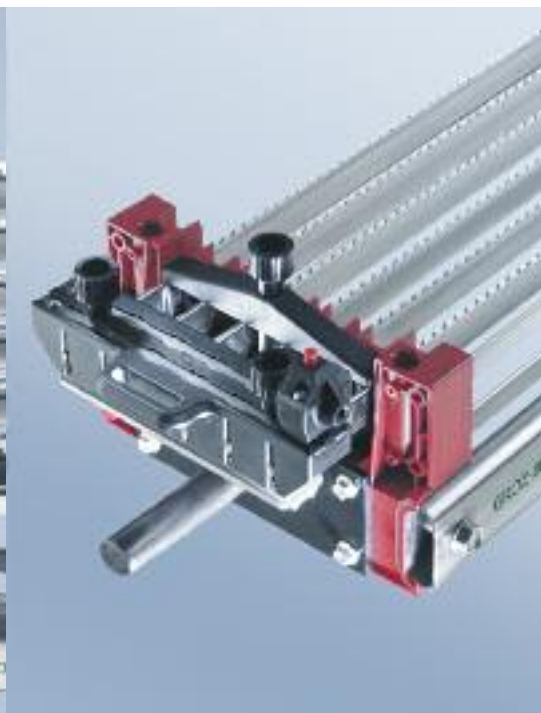

BASIC VERSION OF WARP STOP MOTION KFW 5601.

### Benefits offered by warp stop motion

#### Flexibility:

The warp stop motion facilitates the perfect geometry for warp yarn guidance, extending the scope of application for monitoring even the finest and softest ends.

The meticulously engineered design permits modular variation from the simplest low-cost model through to the deluxe universal model, with its advanced state-of-the-art electronic functionality.

#### Strength:

The compact and stable design is achieved by means of strong, dimensionally-optimized stainless steel thread supporting tubes.

#### Operating safety:

Depending on the model, simple connecting parts or optical thread breakage displays with programmable signal processor (PSP) are used – with optional separation into the left- and right-hand sections of the weaving machine.

#### Adjustability:

The fall height of the drop wires can be adjusted in three positions according to specific weaving requirements. All that is required is the exchange of the plastic supports.

The optimum geometry of the KFW 5600 also facilitates perfect control of warp yarns from fine filaments to heavy staples with warp densities of up to 120 ends per cm.

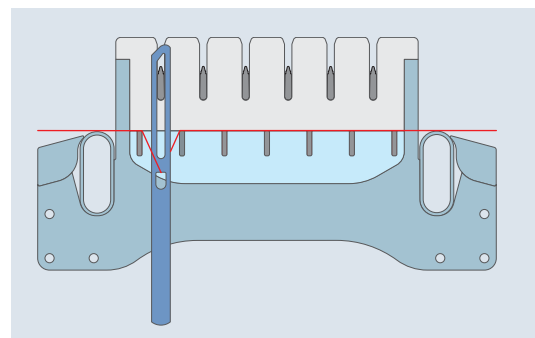

## KFW 5600 – DETAILS

Contact bars and drop wires are maintained in the required position for optimum performance by the intermediate supports and guide bars.



### Universal construction

The KFW 5600 warp stop motion is equipped with six contact bars with a pitch of 25 mm, and is suitable for use with 80 - 85 % of all woven constructions. For the remaining applications such as high-density filament constructions, the KWF 5800 is available with its eight contact rails, while the dual row KFW 4200 is offered specifically for terry applications.

### Compact and stable design

The design is extremely stable, making it ideal to withstand extreme loads over many years of operation. Critical to stability are the extremely strong stainless steel thread supporting tubes measuring 50 x 20 mm and the lateral bar supports made of high

synthetic material. The contact bars and drop wires are maintained in the required position for optimum performance by the intermediate supports and guide bars.

### Quality contact bars









Extremely stable, wear-resistant contact bars measuring 23 x 4 mm are designed for all ranges of application. They are suitable for drop wires with contact bar slots of 4.8 mm in width. The basic versions are available with either a serrated or unserrated inner bar. Both versions are also available with a central interruption to allow indication of yarn breakage in the left- and right hand sections of the weaving machine.

### Optical thread breakage display with programmable signal processor

In the basic version, the easily attachable connecting parts can be optionally supplied with or without LED. In the universal model, connecting parts with optical thread breakage display are used for each contact bar. The processor is designed to permit adjustment of the response sensitivity. With the aid of LEDs, stop motion problems or false machine stoppages can be identified immediately. The stop motion is supplied with power from the weaving machine using convenient standardized plug-in connectors and adjusted cables.

The deluxe universal model offers optical thread breakage indication for individual contact bars.

## TABLE FOR DETERMINATION OF THE MOST SUITABLE WARP STOP MOTION (KFW)

Type	Contact bars					Connecting parts			Warp application				
	Number 	Width 	Height 	Pitch 	Warp passage 	Interrupted 	LED 	Socket 	Spun yarns	Filament yarns	High-density filament yarns	Terry	Water jet machines
KFW 5600	6	4	23	25	18/24/30		•		•	•			
KFW 5620	6	4	23	25	18/24/30	•	•		•	•			
KFW 5601	6	4	23	25	18/24/30			•	•	•			
KFW 5621	6	4	23	25	18/24/30	•		•	•	•			
KFW 5800	8	3,4	13	16	16			•			•		•
KFW 5820	8	3,4	13	16	16	•		•			•		•
KFW 4200-1	2	4	23	30	20			•				•	
KFW 4220-1	2	4	23	30	20	•		•				•	
KFW 4200-2	2	4	23	30	14			•				•	
KFW 4220-2	2	4	23	30	14	•		•				•	

### Transparency

Connecting parts on each side – and contact bars with interrupted inner bars – with indication with LEDs of a warp breakage on the left- or right-hand section of the weaving machine. For particularly aggressive and abrasive warp yarns, thread supporting tubes are available with extremely resistant surface finishes.

### Compatible drop wires

Groz-Beckert customers can also draw on a matching range of drop wires which, working in conjunction with the warp stop motions, ensure efficient monitoring of individual warp yarns. For more information – in addition to the drop wire brochure – go to [www.groz-beckert.com](http://www.groz-beckert.com)

### For monitoring terry, velvet and plush warps

Groz-Beckert warp stop motions KFW 4200 and KFW 4220 are designed for weaving machines with two or more warp beams, and are distinguished by their reliable monitoring of individual ends and their efficient handling. Particular attention was given in the design to provide a clear separation of ground and pile warp yarns.

Identical components are used in both models. The downwardly open design also minimizes accumulation of fly.

### Other equipment features

To ensure that contact bars and drop wires are not damaged by the warp stop motion during shedding, the ground and pile warp stop motions are equipped as standard at the front and rear with retaining devices. The warp stop motions can also be optionally equipped with contact bars with inner bars interrupted in the center to indicate warp breakages on the left- and right-hand sections of the weaving machine. A searching device can also be added aid to additionally simplify the process of locating broken warp yarns.

## KFW 5600 – ADJUSTMENT SCOPE

With a contact bar pitch of 25 mm, these warp stop motions are ideally suited for working with spun warp yarns. Using the following settings, the warp yarns are ideally supported by the guide bars, guaranteeing success-

ful processing even when working with sensitive warps.

As an additional aid to ensure the optimum adjustment of distance plates and lateral bar supports, the distance bet-

ween the thread supporting tubes and the contact bar is shown in mm. When using a retaining device, attention must also be paid to ensure correct adjustment.

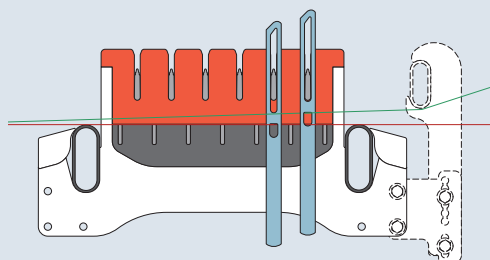
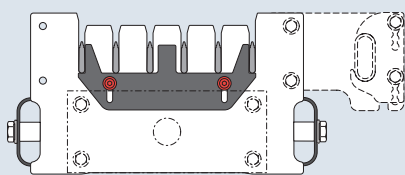

### Red distance plate

Version for the maximum possible drop wire fall height. Distance between thread supporting tube and contact bar: 18 mm.

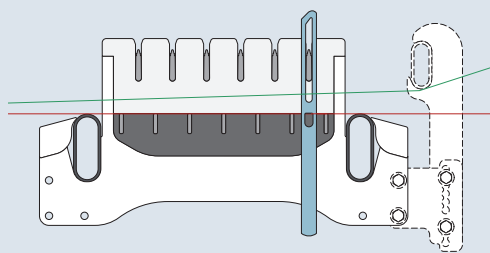
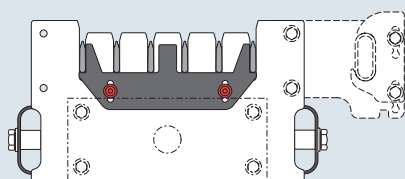

### White distance plate

Standard version with low-position contact bars for optimum drop wire fall height. Distance between thread supporting tube and contact bar: 24 mm.

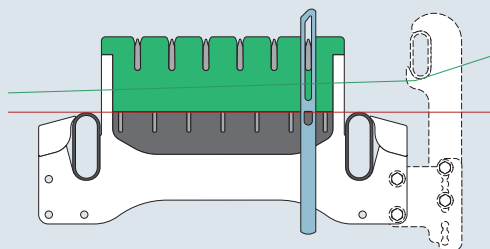
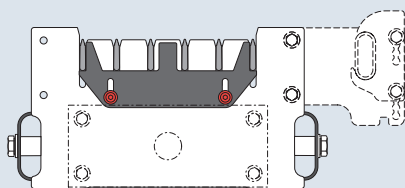

### Green distance plate

Version for minimum drop wire fall height. Distance between thread supporting tube and contact bar: 30 mm.

## KFW 5800 – ADJUSTMENT SCOPE

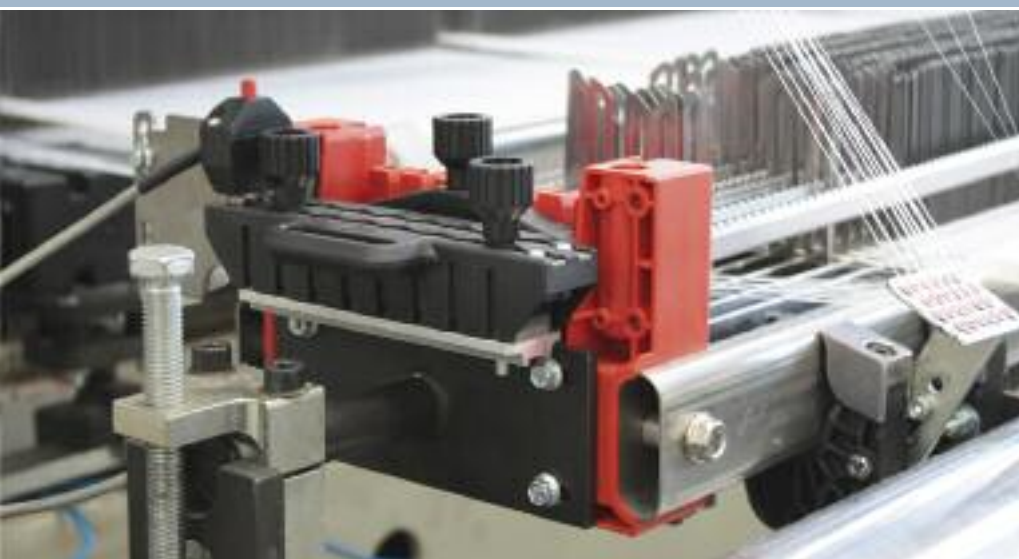

KFW 5800

With a contact bar pitch of 16 mm, these warp stop motions are ideally suited for working with silk and filament warp yarns, and with high warp densities of around 160 ends per cm.

Using the following settings, the warp threads are ideally supported by the guide bars, guaranteeing successful processing even when working with sensitive warps.

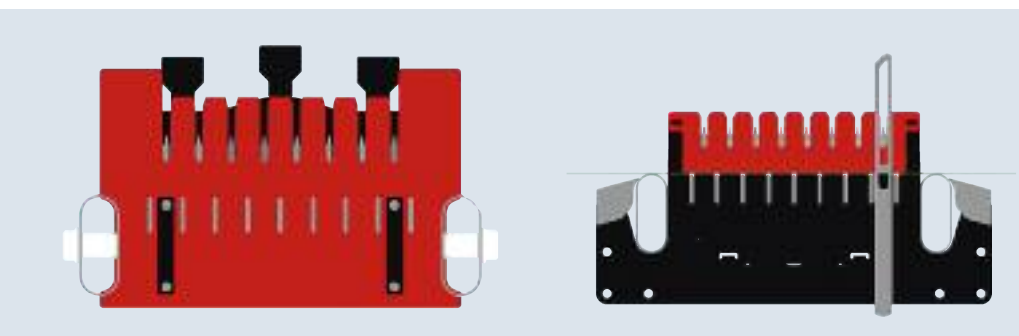

### Red distance plate

Seven guide bars in high-position guarantee optimal support of warp yarns.

GROZ-BECKERT KG  
PO Box 10 02 49  
72423 Albstadt, Germany  
Phone +49 7431 10-0  
Fax +49 7431 10-2777  
sales-w@groz-beckert.com  
www.groz-beckert.com



The depictions provided of our products are not to scale and are intended for illustrative purposes only. Consequently they make no claim to be an accurate representation of the original.

® = Registered trademark of the Groz-Beckert company group.  
© = This publication is copyrighted. All rights reserved, in particular the right of duplication, distribution and translation. This publication or any parts thereof may not be reproduced or stored, processed, duplicated or distributed using electronic systems in any form or by any means whatsoever without the express written consent of Groz-Beckert.